

WEIL-McLAIN

ULTRA SERIES CONDENSING HIGH EFFICIENCY GAS BOILER WEIL MCLAIN



Features:

- Factory tested
- Cast aluminum block
- 30 PSI ASME
- Stainless steel burner
- Direct spark ignition
- Variable speed blower assembly
- Gas/Air ratio venturi with silencer
- Neg. pressure regulation gas valve
- 50 OVA transformer
- Comb. T&P gauge
- Outlet/Return water temp. sensor
- Flue gas temp. sensor
- Outdoor temp. sensor
- Taco 0011 boiler circulator
- Shipped separately with 1" & 1 1/4 flanges
- Complete Jacket with fully removable front cover
- Vent / Air Termination Plate
- Vent Termination Bird Screen
- Line & Low Voltage Pre-wired terminal strips
- Line voltage service receptacle
- Condensate trap with drain tee assembly
- Propane conversion orifice Automatically adapts for high altitude
- Ultra homeowner protection plan with 5 year parts & labor
- Limited 15 year heat exchanger warranty

Model	Input MBtuH Hi/Lo	DOE Cap.	AFUE %	Gas Line Size	Supply Size	Return Size	Dimension HxWxD	Vent Size	Combustion Air Size	Water Content	Wgt.
Ultra 80	80/16	71	93.0	1/2	1	1	41 1/8 x 22 1/8 x 19 1/16	3PVC/ABS	3	0.95	149
Ultra 105	105/21	94	92.0	1/2	1	1	41 1/8 x 22 1/8 x 19 1/16	3PVC/ABS	3	1.07	154
Ultra 155	155/31	139	93.0	1/2	1	1	41 1/8 x 22 1/8 x 19 1/16	3PVC/ABS	3	1.17	193
Ultra 230	203/46	207	92.8	1/2	1	1	41 1/8 x 22 1/8 x 19 1/16	3 or 4PVC/ABS	3 or 4	1.57	204
Ultra 310	310/62	289	93.3	3/4	1 1/4	1 1/4	41 1/8 x 22 1/8 x 19 1/16	4PVC/ABS	4	2.1	254

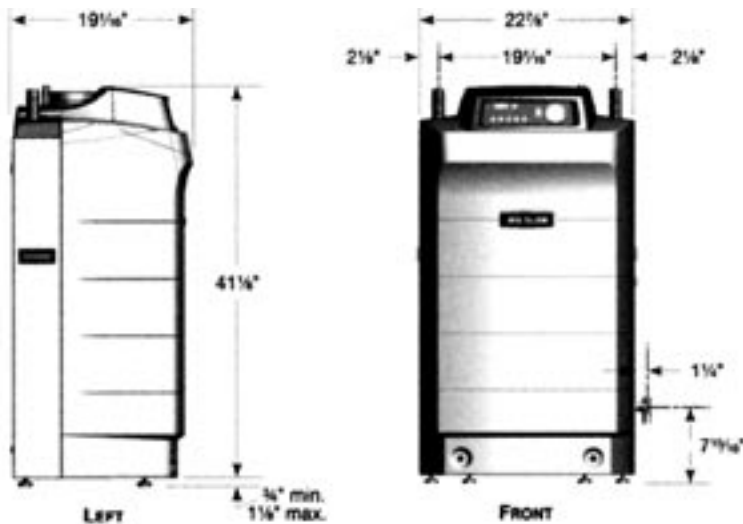

Ultra Control Module Features:

- Digital Display:
- Ignition Control
- Operating Control
- High Limit Protection
- Low Water Protection
- Outdoor Reset
- DHW Priority
- Two Pump Controls (Heating & DHW)

BOILERS & ACCESSORIES

WEIL-McLAIN

GOLD GV SERIES GAS BOILER WEIL MCLAIN



Features:

- Category III Sealed Combustion with 3" AL249C Stainless Steel
- GCM Gold Control Module w/Indicator Lights
- Gas/Air Manifold Assembly
- Stainless Steel Burner Cone and Ring Assembly
- Standard Equipment Includes: System Circulator, 30 PSI P/T Valve, Hot Surface Ignition, 40 VA Transformer, & Natural to LP Conversion Kit
- Warranty: 1 year all parts; Limited Lifetime heat exchanger (10 years commercial)



Model	Input MBtuH	Output MBtuH	AFUE Efficiency	Supply Size	Return Size	Dimension HxWxD	Vent Size	Gas Line Size	Wgt.
GV-3	70	61	87.5	1	1	29 ³ / ₄ X17 ⁵ / ₈ X37 ³ / ₄	3	1/2	270
GV-4	105	92	87.3	1	1	29 ³ / ₄ X17 ⁵ / ₈ X37 ³ / ₄	3	1/2	320
GV-5	140	122	87.2	1	1	29 ³ / ₄ X17 ⁵ / ₈ X37 ³ / ₄	3	1/2	355
GV-6	175	153	87.0	1	1	29 ³ / ₄ X17 ⁵ / ₈ X37 ³ / ₄	3	1/2	410

AHE SERIES GAS BOILER WATER WEIL MCLAIN



Features:

- Wall Mounted Cast Iron Construction
- Direct Vent Sealed Combustion
- Aluminized Steel Burners
- Combination Gas Control Valve
- Standard Equipment Includes: Vent Kit, System Circulator, Auto Air Vent, 30 PSI P/T Valve, Hot Surface Ignition, & 40 VA Transformer.
- LP or Natural Gas
- Warranty: 1 year all parts; 10 Year Heat Exchanger



Model	Input MBtuH	DOE Cap.	AFUE Efficiency	Supply Size	Return Size	Dimension LxWxH	Vent Size	Gas Line Size	Wgt.
AHE-45	45	38	85.3	3/4	3/4	36x19 ¹ / ₂ X24 ¹ / ₂	3	3/8	175
AHE-60	60	51	85.5	3/4	3/4	36x19 ¹ / ₂ X24 ¹ / ₂	3	3/8	215

BOILERS & ACCESSORIES

WEIL-McLAIN

CGS SERIES GAS BOILER WEIL MCLAIN



Features:

- Direct Vent Sealed Combustion or Non-direct Vent with 3" AL249C Stainless Steel Venting
- Stainless Steel Burners
- Ignition Control with Self Diagnostics
- Standard Equipment Includes: System Circulator, 30 PSI P/T Valve, Indirect Spark Ignition, Sidewall Vent Kit, & 40 VA Transformer.
- LP or Natural Gas
- Warranty: 1 year all parts; Limited Lifetime heat exchanger (10 years commercial)



Model*	Input MBtuH	Output MBtuH	AFUE Efficiency	Supply Size	Return Size	Dimension HxWxD	Vent Size	Gas Line Size	Wgt.
CGs-3	67	57	85.3	1 ¹ / ₄	1	28 ³ / ₈ x13x23 ¹ / ₄	3	1/2	240
CGs-4	100	85	84.6	1 ¹ / ₄	1	28 ³ / ₈ x16x23 ¹ / ₄	3	1/4	280
CGs-5	133	112	84.0	1 ¹ / ₄	1	28 ³ / ₈ x19x23 ¹ / ₄	3	1/2	325
CGs-6	167	140	83.4	1 ¹ / ₄	1 ¹ / ₄	28 ³ / ₈ x22x23 ¹ / ₄	3	1/2	370

*Add "PIN" for Natural Gas, "PIL" for Propane Gas

WEIL-McLAIN

CGA SERIES GAS BOILER WEIL MCLAIN



Features:

- SPD w/Standing Burners
- PID w/Intermittent Electronic Ignition System
- Stainless Steel Burners
- Cast iron sections with elastomer seals
- Large faced temp and pressure gauges
- Automatic vent damper
- Limited Lifetime Warranty On Water Boiler Sections
- 10 Year Warranty On Steam Boiler Sections

Model	Input MBtuH	Output MBtuH	AFUE Efficiency	Supply Size	Return Size	Dimension HxWxD	Vent Size	Gas Line Size	Wgt.
CGa-25PIDN	52	44	84.0	3/4	3/4	28 ³ / ₈ x10x23 ¹ / ₄	4	1/2	200
CGa-25SPDN	52	44	81.5	3/4	3/4	28 ³ / ₈ x10x23 ¹ / ₄	4	1/2	200
CGa-3PIDN	70	59	84.0	1	1	28 ³ / ₈ x10x23 ¹ / ₄	4	1/2	200
CGa-3SPDN	70	59	81.6	1	1	28 ³ / ₈ x10x23 ¹ / ₄	4	1/2	200
CGa-4PIDN	105	88	84.0	1	1	28 ³ / ₈ x13x23 ¹ / ₄	5	1/2	240
CGa-4SPDN	105	88	81.7	1	1	28 ³ / ₈ x13x23 ¹ / ₄	5	1/2	240
CGa-5PIDN	140	117	83.5	1	1	28 ³ / ₈ x16x23 ¹ / ₄	6	1/2	280
CGa-5SPDN	140	117	81.8	1	1	28 ³ / ₈ x16x23 ¹ / ₄	6	1/2	280
CGa-6PIDN	175	146	83.2	1 ¹ / ₄	1 ¹ / ₄	28 ³ / ₈ x19x23 ¹ / ₄	6	1/2	325
CGa-6SPDN	175	146	81.9	1 ¹ / ₄	1 ¹ / ₄	28 ³ / ₈ x19x23 ¹ / ₄	6	1/2	325
CGa-7PIDN	210	175	83.0	1 ¹ / ₄	1 ¹ / ₄	28 ³ / ₈ x22x23 ¹ / ₄	7	3/4	370
CGa-7SPDN	210	175	82.0	1 ¹ / ₄	1 ¹ / ₄	28 ³ / ₈ x22x23 ¹ / ₄	7	3/4	370
CGa-8PIDN	245	204	83.0	1 ¹ / ₂	1 ¹ / ₂	28 ³ / ₈ x25x23 ¹ / ₄	7	3/4	425
CGa-8SPDN	245	204	82.1	1 ¹ / ₂	1 ¹ / ₂	28 ³ / ₈ x25x23 ¹ / ₄	7	3/4	425

GOLD CGI SERIES 2 GAS BOILER WEIL MCLAIN



Features:

- Hot water, Direct Exhaust (Induced Draft) Category III
- Natural Draft Category I
- Stainless Steel Burners
- Cast iron sections with elastomer seal
- Compact design
- Improved parts kits
- Advanced one way wiring connections
- Factory tested
- Control Module & Ignition Control
- Limited Lifetime Warranty

Model	Input MBtuH	Output MBtuH	AFUE Efficiency	Supply Size	Return Size	Dimension HxWxD	Vent Size	Gas Line Size	Wgt.
CGi-25	50	42	83.0	1 ¹ / ₄	3/4	28 ³ / ₈ x10x23 ¹ / ₄	4	1/2	190
CGi-3	67	57	83.3	1 ¹ / ₄	1	28 ³ / ₈ x10x23 ¹ / ₄	4	1/2	190
CGi-4	100	85	83.0	1 ¹ / ₄	1	28 ³ / ₈ x13x23 ¹ / ₄	5	1/2	230
CGi-5	133	112	82.7	1 ¹ / ₄	1	28 ³ / ₈ x16x23 ¹ / ₄	5	1/2	270
CGi-6	167	140	82.4	1 ¹ / ₄	1 ¹ / ₄	28 ³ / ₈ x19x23 ¹ / ₄	5	1/2	315
CGi-7	200	167	82.1	1 ¹ / ₄	1 ¹ / ₄	28 ³ / ₈ x22x23 ¹ / ₄	5	3/4	360
CGi-8	233	194	82.7	1 ¹ / ₂	1 ¹ / ₂	28 ³ / ₈ x25x23 ¹ / ₄	5	3/4	425

*Add "PIN" for Natural Gas, "PIL" for Propane Gas

WEIL-McLAIN

GOLD WGO SERIES OIL WATER BOILER WEIL MCLAIN



Features:

- Dedicated Water-Only Boiler
- Swinging Burner Door & Top Cleaning For Service Ease
- Back or Top Venting
- Factory Assembled w/Jacket, Circulator, 30 PSI Pressure Relief Valve, Burner, Draft Control & Controls
- Warranty: 1 year all parts; Limited Lifetime heat exchanger (10 years commercial)



Model*	IBR Cap	DOE Cap GPH	AFUE MBtuH	Supply Size	Return Size	Dimension HxWxD	Vent Size	Wgt. Size
WGO-2	0.70	86	86.4	1 ¹ / ₄	1 ¹ / ₂	35 ⁵ / ₈ X20 ¹ / ₄ X13 ³ / ₄	6	540
WGO-3	0.95	115	85.3	1 ¹ / ₄	1 ¹ / ₂	35 ⁵ / ₈ X20 ¹ / ₄ X16 ⁷ / ₈	6	595
WGO-4	1.20	145	85.0	1 ¹ / ₄	1 ¹ / ₂	35 ⁵ / ₈ X20 ¹ / ₄ X16 ⁷ / ₈	6	645
WGO-5	1.45	175	85.0	1 ¹ / ₂	1 ¹ / ₂	35 ⁵ / ₈ X20 ¹ / ₄ X20	7	760
WGO-6	1.75	212	85.0	1 ¹ / ₂	1 ¹ / ₂	35 ⁵ / ₈ X20 ¹ / ₄ X23 ¹ / ₈	7	860
WGO-7	2.00	242	85.0	1 ¹ / ₂	1 ¹ / ₂	35 ⁵ / ₈ X23 ¹ / ₈ X26 ¹ / ₄	7	930
WGO-8	2.30	266		1 ¹ / ₂	1 ¹ / ₂	35 ⁵ / ₈ X26 ¹ / ₄ X29 ³ / ₈	8	1,030
WGO-9	2.55	295		1 ¹ / ₂	1 ¹ / ₂	35 ⁵ / ₈ X29 ³ / ₈ X32 ¹ / ₂	8	1,135

*Add "P" for Packaged boiler (WGO-2 through WGO-6 only) Substitute A for boiler only (2 through 9)

GOLD SGO SERIES OIL STEAM BOILER WEIL MCLAIN



Features:

- Tankless Heater Opening
- Two vent pipe brackets
- Swing away burner mounting door
- Drain Valve
- Factory Assembled w/Jacket, Burner & Controls
- Optional 5 or ten year homeowner protection plan.
- Limited 10 year warranty on boiler sections.



Model*	IBR Cap GPH	DOE Cap MBtuH	AFUE Efficiency	Supply Size	Return Size	Dimension HxWxD	Vent Size	Wgt.
SGO-3	0.95	114	84.1	1 ¹ / ₂ -2 ¹ / ₂	2	35 ⁵ / ₈ X20 ¹ / ₄ X16 ⁷ / ₈	6	600
SGO-4	1.20	144	84.0	1 ¹ / ₂ -2 ¹ / ₂	2	35 ⁵ / ₈ X20 ¹ / ₄ X20	6	705
SGO-5	1.45	174	83.9	1 ¹ / ₂ -2 ¹ / ₂	2	35 ⁵ / ₈ X20 ¹ / ₄ X23 ¹ / ₈	7	820
SGO-6	1.75	210	83.7	2 ¹ / ₂	2	35 ⁵ / ₈ X20 ¹ / ₄ X26 ¹ / ₄	7	920
SGO-7	2.00	240	83.6	2 ¹ / ₂	2	35 ⁵ / ₈ X20 ¹ / ₄ X29 ³ / ₈	8	990
SGO-8	2.30	266		2 ¹ / ₂	2	35 ⁵ / ₈ X20 ¹ / ₄ X32 ¹ / ₂	8	1,090
SGO-9	2.55	295		2 ¹ / ₂	2	35 ⁵ / ₈ X20 ¹ / ₄ X35 ⁵ / ₈	8	1,195

*Add "P" for Packaged boiler.(WG02 through WGO 6 only)Substitute A for boiler only (2-9)

BOILERS & ACCESSORIES

WEIL-McLAIN

WTGO SERIES OIL HOT WATER BOILER W/ TANKLESS HEATER



Features:

- Dedicated water-only boiler
- Swinging burner door & top cleaning for service ease
- Back or top venting
- Factory assembled w/jacket, circulator, 30 psi pressure relief valve, burner, draft control & controls
- Warranty: 1 year all parts; limited lifetime heat exchanger (10 years commercial)

Optional equipment:

- High efficiency flame retention oil burner (Beckett AFG, Carlin EZ or Riello) specify two stage fuel unit (optional) if required.
- Tankless heaters and controls.
- Three piece circulators - Taco 110 or G&G100
- Weil McLain 5 year or 10 year homeowner protection plan



EPA POLLUTION PREVENTER

Model*	IBR Cap GPH	DOE Cap MBtuH	AFUE	Supply Size	Return Size	Dimension HxWxD	Vent Size	Wgt. Size
WTGO-3	0.95	115	85.3	1/4	1/2	35 ⁵ / ₈ x20 ¹ / ₄ x16 ⁷ / ₈	6	540
P-WTGO-3L	0.95	115	85.3	1/4	1/2	35 ⁵ / ₈ x20 ¹ / ₄ x13 ³ / ₄	6	595
WTGO-4	1.20	145	85.0	1/4	1/2	35 ⁵ / ₈ x20 ¹ / ₄ x16 ⁷ / ₈	6	645
WTGO-5	1.45	175	85.0	1/2	1/2	35 ⁵ / ₈ x20 ¹ / ₄ x20	7	760
WTGO-6	1.75	212	85.0	1/2	1/2	35 ⁵ / ₈ x20 ¹ / ₄ x23 ¹ / ₈	7	860
WTGO-7	2.00	242	85.0	1/2	1/2	35 ⁵ / ₈ x23 ¹ / ₈ x26 ¹ / ₄	7	930
WTGO-8	2.30	266		1/2	1/2	35 ⁵ / ₈ x26 ¹ / ₄ x29 ³ / ₈	8	1,030
WTGO-9	2.55	295		1/2	1/2	35 ⁵ / ₈ x29 ³ / ₈ x32 ¹ / ₂	8	1,135

*Add "P" for Packaged boiler (WGO-2 through WGO-6 only) Substitute A for boiler only (2 through 9)

GOLD PLUS & PLUS INDIRECT-FIRED WATER HEATER WEIL MCLAIN



Features:

- Tank-Within-Tank Design
- 2 Polyurethane Foam Insulation
- Stainless Steel Inner Tank & Carbon Steel Outer Tank
- Drain Valve Assembly
- For use with Weil-McLain Gas and Oil Boilers
- Limited Lifetime Warranty on Gold Plus Boilers
- 15 Year Limited Warranty on Plus Boilers

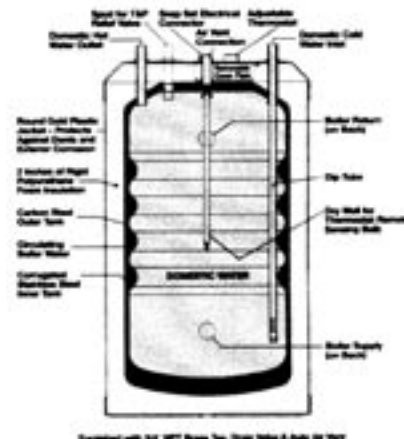

BOILERS & ACCESSORIES

Model	Capacity Gal.	1st Hr.Flow GPH@115° 210MBtuH	1st Hr.Flow GPH@140° 210MBtuH	Hgt.	Dia.	DHW Conn. NPT	Boiler Conn. NPT	Wgt
Plus 30 GOLD	28	230	140	38	22	3/4	1	135
Plus 40 GOLD	36	260	170	46	22	3/4	1	155
Plus 60 GOLD	46	365	220	57	22	3/4	1 1/4	180
Plus 80 GOLD	56	440	330	66 1/2	22	3/4	1 1/4	200
Plus 100	76	455	340	62 1/2	22	1 1/2	2	370
Plus 120	120	510	375	73 1/4	22	1 1/2	2	450

WEIL-McLAIN

LGB SERIES GAS BOILER WATER & STEAM WEIL MCLAIN



Features:

- Natural Draft Venting
- Factory Assembled Burner & Base
- Built in air separator
- Vertical draft hood (packed separately)
- Aluminized steel burners
- 81% operating efficiency
- Factory assembled gas train
- Extra large 9" top port opening
- Ten Year Limited Warranty

Model	Input MBTUH	Output MBTUH	IBR Water	IBR Steam	Supply Size ¹	Return Size ¹	Dimension HxWxD	Vent Size	NG Supply		Wgt.
									5" WC	7" WC	
*LGB-4**	400	324	243	282	2	2	50 ³ / ₈ x21x64 ¹ / ₂	10	1	1	1185
*LGB-5**	520	421	316	366	2 ¹ / ₂	2 ¹ / ₂	50 ³ / ₈ x26x64 ¹ / ₂	12	1	1	1455
*LGB-6**	650	527	395	458	3	3	50 ³ / ₈ x31x64 ¹ / ₂	12	1 ¹ / ₄	1	1725
*LGB-7**	780	632	474	549	3	3	50 ³ / ₈ x36x64 ¹ / ₂	12	1 ¹ / ₄	1	2005
*LGB-8**	910	737	553	641	3	3	50 ³ / ₈ x41x64 ¹ / ₂	14	1 ¹ / ₄	1	2290
*LGB-9**	1040	842	632	733	4	4	50 ³ / ₈ x46x64 ¹ / ₂	14	1 ¹ / ₄	1	2560
*LGB-10**	1170	948	711	824	4	4	50 ³ / ₈ x51x64 ¹ / ₂	16	1 ¹ / ₂	1 ¹ / ₄	2800
*LGB-11**	1300	1053	790	916	4	4	50 ³ / ₈ x56x64 ¹ / ₂	16	2	1 ¹ / ₄	3105
*LGB-12**	1430	1158	869	1007	4	4	50 ³ / ₈ x61x64 ¹ / ₂	16	2	1 ¹ / ₄	3365
*LGB-13**	1560	1264	949	1099	4	4	50 ³ / ₈ x66x64 ¹ / ₂	16	1 ¹ / ₄	1	3785
*LGB-14**	1690	1369	1035	1190	4	4	50 ³ / ₈ x71x64 ¹ / ₂	16	1 ¹ / ₄	1	4085
*LGB-15	1820	1474	1123	1282	4	4	50 ³ / ₈ x76x64 ¹ / ₂	16	1 ¹ / ₄	1	4355
*LGB-16	1950	1580	1211	1373	4	4	50 ³ / ₈ x81x64 ¹ / ₂	17	1 ¹ / ₄	1	4725
*LGB-17	2080	1685	1298	1465	5	5	50 ³ / ₈ x86x64 ¹ / ₂	17	1 ¹ / ₄	1	4975
*LGB-18	2210	1790	1386	1557	5	5	50 ³ / ₈ x91x64 ¹ / ₂	18	1 ¹ / ₄ / 1 ¹ / ₂	1 ¹ / ₄ / 1	5270
*LGB-19	2340	1895	1470	1648	5	5	50 ³ / ₈ x96x64 ¹ / ₂	18	1 ¹ / ₂	1 ¹ / ₄	5540
*LGB-20	2470	2001	1553	1740	5	5	50 ³ / ₈ x101x64 ¹ / ₂	19	1 ¹ / ₂ / 2	1 ¹ / ₄	5820
*LGB-21	2600	2106	1635	1831	5	5	50 ³ / ₈ x106x64 ¹ / ₂	19	2	1 ¹ / ₄	6080
*LGB-22	2730	2211	1717	1923	5	5	50 ³ / ₈ x111x64 ¹ / ₂	19	2	1 ¹ / ₄	6365
*LGB-23	2860	2317	1799	2014	5	5	50 ³ / ₈ x116x64 ¹ / ₂	20	2	1 ¹ / ₄	6625

*Add "A" for Factory-Assembled sections, "P" for Fire-Tested package unit**Add "S" for Steam, "W" for Water (LGB 4-14); ¹ Minimum water piping sizes

PFG SERIES GAS BOILER WEIL MCLAIN



Features:

- PIN Intermittent Electronic Ignition System
- SPN Standing Pilot System
- Combination Pressure-Temperature Gauge
- Vertical Draft Hood
- Convenient servicing, easily accessible controls, top cleaning, vertical flueways
- Built in air separator
- Plug in circulator relay

Model	Input MBtuH	Output MBtuH	AFUE Efficiency	Supply Size	Return Size	Dimension HxWxD	Vent Size	Gas line Size	Wgt.
PFG-5-PIN	244	199	81.0	2	2	30 ¹ / ₄ x17 ¹¹ / ₁₆ x34 ¹ / ₂	7	3/4	500
PFG-6-PIN	305	247	81.0	2	2	30 ¹ / ₄ x20 ¹¹ / ₁₆ x34 ¹ / ₂	8	3/4	575
PFG-6-SPN	305	247	81.0	2	2	30 ¹ / ₄ x20 ¹¹ / ₁₆ x34 ¹ / ₂	8	3/4	575
PFG-7-PIN	366	296	81.0	2	2	30 ¹ / ₄ x23 ¹¹ / ₁₆ x34 ¹ / ₂	9	3/4	635
PFG-7-SPN	366	296	81.0	2	2	30 ¹ / ₄ x23 ¹¹ / ₁₆ x34 ¹ / ₂	9	3/4	635
PFG-8-PIN	427	346	81.0	2	2	30 ¹ / ₄ x26 ¹¹ / ₁₆ x34 ¹ / ₂	9	1	695

WEIL-McLAIN

EG SERIES GAS BOILER WATER & STEAM WEIL MCLAIN



Features:

- SPD with Standing Burners
- PID with Intermittent Electronic Ignition System
- Stainless Steel Burners
- Factory Assembled Section
- Limited Lifetime Warranty On Water Boiler Sections
- 10 Year Warranty On Steam Boiler Sections

Model	Input MBtuH	DOE Cap.	AFUE Water	AFUE Steam	Supply Size	Return Size	Dimension HxWxD	Vent Size	Gas Line Size	Wgt.
EG-30SPDN	75	62	82.2	81.0	3	2 ¹ / ₂	33 ³ / ₄ x17x27 ⁵ / ₈	5	1/2	380
EG-30PIDN	75	62	84.3	83.0	3	2 ¹ / ₂	33 ³ / ₄ x17x27 ⁵ / ₈	5	1/2	380
EG-35SPDN	100	83	82.0	81.3	3	2 ¹ / ₂	33 ³ / ₄ x17x27 ⁵ / ₈	5	1/2	380
EG-35PIDN	100	83	83.6	82.9	3	2 ¹ / ₂	33 ³ / ₄ x17x27 ⁵ / ₈	5	1/2	380
EG-40SPDN	125	104	82.5	81.5	3	2 ¹ / ₂	33 ³ / ₄ x21 ¹ / ₄ x27 ⁵ / ₈	6	1/2	465
EG-40PIDN	125	104	84.0	82.9	3	2 ¹ / ₂	33 ³ / ₄ x21 ¹ / ₄ x27 ⁵ / ₈	6	1/2	465
EG-45SPDN	150	125	82.5	81.6	3	2 ¹ / ₂	33 ³ / ₄ x21 ¹ / ₄ x27 ⁵ / ₈	6	1/2	465
EG-45PIDN	150	125	83.5	82.9	3	2 ¹ / ₂	33 ³ / ₄ x21 ¹ / ₄ x27 ⁵ / ₈	6	1/2	465
EG-50SPDN	175	145	82.9	81.9	3	2 ¹ / ₂	33 ³ / ₄ x25 ¹ / ₂ x27 ⁵ / ₈	7	1/2	545
EG-50PIDN	175	145	83.8	82.8	3	2 ¹ / ₂	33 ³ / ₄ x25 ¹ / ₂ x27 ⁵ / ₈	7	1/2	545
EG-55SPDN	200	167	82.5	81.9	3	2 ¹ / ₂	33 ³ / ₄ x25 ¹ / ₂ x27 ⁵ / ₈	7	1/2	545
EG-55PIDN	200	167	83.8	82.8	3	2 ¹ / ₂	33 ³ / ₄ x25 ¹ / ₂ x27 ⁵ / ₈	7	1/2	545
EG-65SPDN	250	209	82.6	82.0	3	2 ¹ / ₂	33 ³ / ₄ x29 ³ / ₄ x27 ⁵ / ₈	8	3/4	630
EG-65PIDN	250	209	84.0	83.0	3	2 ¹ / ₂	33 ³ / ₄ x29 ³ / ₄ x27 ⁵ / ₈	8	3/4	630
EG-75SPDN	300	240			3	2 ¹ / ₂	33 ³ / ₄ x34x27 ⁵ / ₈	8	3/4	695
EG-75PIDN	300	240			3	2 ¹ / ₂	33 ³ / ₄ x34x27 ⁵ / ₈	8	3/4	695

EGH SERIES COMMERCIAL GAS BOILER WEIL MCLAIN



Features:

- Stainless steel burners
- Automatic vent damper
- Horizontal draft hood
- Factory assembled sections

For water boilers:

- Built in air separator
- 30 PSI ASME Relief valve combo pressure-temperature gauge
- High limit control (dual limit control for standard efficiency models)

For steam boilers

- 15 PSI ASME Relief valve steam pressure gauge
- High limit pressure control (two limit controls for standard efficiency models)
- Syphon
- Gauge cocks and glass
- Low-water cut off - electrode type

Model	Input MBtuH	Output MBtuH	AFUE Water	AFUE Steam	Supply Size	Return Size	Dimension HxWxD	Vent Size	Gas Line Size	Wgt.
EGH-85PI*	350	280	243	210	3	2 ¹ / ₂	33 ³ / ₄ x38 ¹ / ₄ x27 ⁵ / ₈	9	3/4	870
EGH-85*	350	280	243	210	3	2 ¹ / ₂	33 ³ / ₄ x38 ¹ / ₄ x27 ⁵ / ₈	9	3/4	870
EGH-95PI*	400	320	278	240	3	2 ¹ / ₂	33 ³ / ₄ x42 ¹ / ₂ x27 ⁵ / ₈	10	1	960
EGH-95*	400	320	278	240	3	2 ¹ / ₂	33 ³ / ₄ x42 ¹ / ₂ x27 ⁵ / ₈	10	1/2	960
EGH-105PI*	450	360	313	270	3	2 ¹ / ₂	33 ³ / ₄ x46 ³ / ₄ x27 ⁵ / ₈	10	1/2	1040
EGH-115PI*	500	400	348	300	3	2 ¹ / ₂	33 ³ / ₄ x51x27 ⁵ / ₈	12	1/2	1135
EGH-125PI*	550	440	383	330	3	2 ¹ / ₂	33 ³ / ₄ x55 ¹ / ₄ x27 ⁵ / ₈	12	1/2	1215

*Add "W" for Water, "S" for Steam

WEIL-McLAIN

MODEL 80 COMMERCIAL BOILER WEIL MCLAIN



Features:

- Light oil, gas, and gas / light oil
- 10 sizes from 208-1172 MBtuH
- Water or steam
- Convertible flue: top or rear flue
- Factory assembly available
- Hydro-wall design: water circulates completely around chamber
- Up to 4 tankless heaters
- Wide selection of burners including Beckett, Carlin, Gordon-Piatt, Power Flame, & Webster
- Unique, easy-access jacket design requires no tool for removal
- Standard equipment water: cast iron sections, insulated jacket, burner (except H-80), observation ports, side cleanout plates, flue brush, 30 PSIG relief valve, combination low limit & high limit control, tridicator, and air eliminator
- Standard equipment steam: cast iron sections, insulated jacket, burner (except H-80), observation ports, side cleanout plates, flue brush, 15 PSIG relief valve, low and high limit pressure control, steam pressure gauge, gauge glass, gauge cock, and gauge guards.
- Options: low water cut off, tankless heaters, factory assembled sections, fire tested packaged boiler

Model	IBR Cap.		Gross IBR Output	Net IBR Rating			Boiler HP	Size HxWxD	Vent Size	Water Cont.		Pkg. Wgt.
	Lgt Oil GPH	Gas MBtuH		Steam Ft ²	Steam MBtuH	Water MBtuH				Water	Steam	
380	2.40	346	278	867	208	242	8.3	57 ⁹ / ₁₆ X29 ⁷ / ₈ X13 ¹ / ₈	8	37.5	27.5	1058
480	3.40	491	396	1238	297	344	11.8	57 ⁹ / ₁₆ X29 ⁷ / ₈ X20 ¹ / ₈	8	49.0	36.0	1203
580	4.45	639	515	1608	386	448	15.4	57 ⁹ / ₁₆ X29 ⁷ / ₈ X27 ¹ / ₈	8	60.5	44.5	1448
680	5.50	787	634	1983	476	551	18.9	57 ⁹ / ₁₆ X29 ⁷ / ₈ X34 ¹ / ₈	8	72.0	53.0	1843
780	6.50	753	753	2354	565	655	22.5	57 ⁹ / ₁₆ X29 ⁷ / ₈ X41 ¹ / ₈	10	83.5	61.5	2088
880	7.50	1082	872	2725	654	758	26.0	57 ⁹ / ₁₆ X29 ⁷ / ₈ X48 ¹ / ₈	10	95.0	70.0	2317
980	8.50	1230	991	3096	743	862	29.6	57 ⁹ / ₁₆ X29 ⁷ / ₈ X55 ¹ / ₈	10	106.5	78.5	2678
1080	9.60	1378	1110	3471	833	965	33.2	57 ⁹ / ₁₆ X29 ⁷ / ₈ X62 ¹ / ₈	10	118.0	87.0	2923
1180	10.6	1526	1229	3842	922	1069	36.7	57 ⁹ / ₁₆ X29 ⁷ / ₈ X69 ¹ / ₈	10	129.5	95.5	3068
1280	11.6	1674	1348	4242	1018	1172	40.3	57 ⁹ / ₁₆ X29 ⁷ / ₈ X76 ¹ / ₈	12	141.0	104.0	3313

BOILERS & ACCESSORIES

Buderus

HYDRONIC SYSTEMS

LOGANO G115 SERIES OIL BOILER BUDERUS



Features:

- Flexible Corrosion Resistant GL-180M Cast Iron
- Full Swing Door for Serviceability
- Three Pass Flue Design
- Chimney Vent or Sealed Combustion Pressure Fired

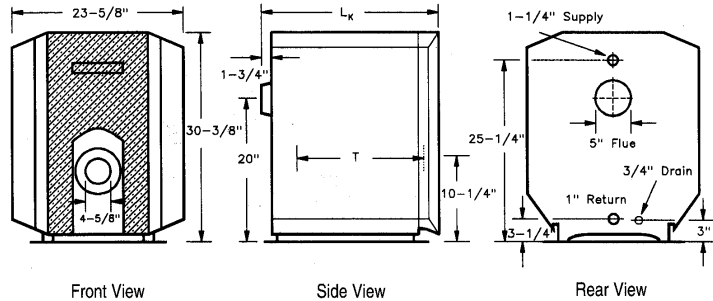

Model	Boiler Size	# Sections	Firing Rate	DOE MBtuH	Net MBtuH	AFUE	HxWxL	Flue Size	Water Content	Wgt.
G-115	21	3	0.60	74	64	86.5	23 ^{5/8} x30 ^{3/8} x21 ^{1/4}	5	8.7	331
G-115	28	4	0.80	98	85	86.8	23 ^{5/8} x30 ^{3/8} x25 ^{3/4}	5	10.8	403
G-115	34	5	1.00	120	104	86.0	23 ^{5/8} x30 ^{3/8} x30 ^{1/2}	5	12.9	476

Burner Type	Description	Order # G-115-21	Order # G-115-28	Order # G-115-34
Riello F3	Chimney Vent	12-11521KP	12-11538KP	12-11534KP
Riello F5	Chimney Vent	11-11521KP	11-11528KP	11-11534KP
Beckett AFII	Chimney Vent	13-11521KP	13-11528KP	13-11534KP
Carlin	Chimney Vent	12-11521BFPK	12-11528BFPK	12-11534BFPK
Riello BF3	Direct Vent Kit	13-11521P10KP	13-11528P10KP	13-1153P10KP
Riello BF5				
Carlin P10				
FH4X10	Flex Vent Pipe 4" x 10'			
FT4	Fields Termination Kit			

Standard B-Kit Accessories

Included with the Boiler Are:
Tridicator, 30lb. Press. Relief, 1/4" Supply Manifold, 3/4" Boiler Drain
KP Kit Option: Custom Burner (see table left) with Circulator, Flanges, **L8148A** Aquastat, and Flexible Oil Line
With Using the Ecomatic Control Deduct **L8148A** Aquastat

BOILERS & ACCESSORIES

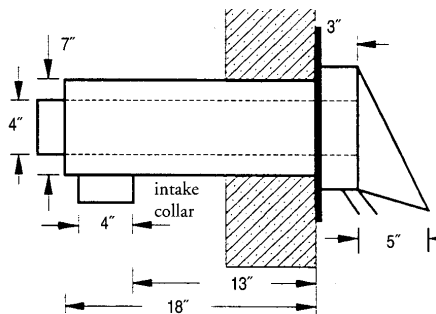

FT-4 Concentric pipe-in-pipe termination.

	G115 and LT Tank Stackable Options		
	G115-21	G115-28	G115-34
LT135	XX	XX	
LT160	XX	XX	
LT200	XX	XX	XX
LT300	XX	XX	XX

